

RS 400 Door

Owner's Manual

RollSeal
PO Box 140
1751 County Road 68
Bremen, Alabama 35033

Table of Contents

Section	Description	Page
1.	Ratings and Specifications	3
2.	Warnings	4
3.	Limited Warranty	5
4.	Physical Description/Drawing	6
5.	Installation	6
5.1	Operator Power options	7
5.2	Tools Required.....	7
5.3	Overview	7
5.4	Adjusting the Clear Opening	7
5.5	Attachment Points of Door	8
5.6	Assembly of Parts	9
5.6.1	Assembly of Head Unit and Tracks	9
5.6.2	Fastening Door Assembly to Clear Opening.....	10
5.6.3	Safety Bracket.....	11
5.6.4	Chain Hoist Installation	12
5.6.5	Manaras Operator.....	13
5.6.5.1	Installation of Manaras Operator.....	13
5.6.5.2	Mounting the Manaras Operator	14
5.6.5.3	Spreader, Sprocket, and Chain Installation	15
5.6.5.4	Limit Switches	17
5.6.5.5	Adjustment of Limit Switches.....	17
5.6.5.6	Minimum Suggested Wire Size for Control Circuit.....	18
5.6.5.7	Wiring of the Manaras Operator	19
5.6.5.8	Main Power Supply	19
5.6.5.9	Wiring Options to the Manaras Operator Terminal Block.....	21
5.6.6	Curtain Installation.....	21
5.6.7	Door Curtain Adjustments	22
5.6.8	Install Horizontal Member Covers.....	23
6.	Operation of Door	24
6.1	Manual Operation with Chain Hoist.....	24
6.2	Switch Operation with Manaras Operator	24
6.3	Manual Operation with Manaras Operator	25
7.	Adjustment Procedures	26
8.	Manaras Optional Parts.....	27

Please Retain This Manual for Future Reference

1. Ratings and Specifications

The RS 400 door provides manual or automatic operation of rollup fabric for industrial installations. The RS 400 doors are intended for moderate exposure and moderate wind conditions. Framing dimensions of the RS400 doors are shown in the following diagram and tables.

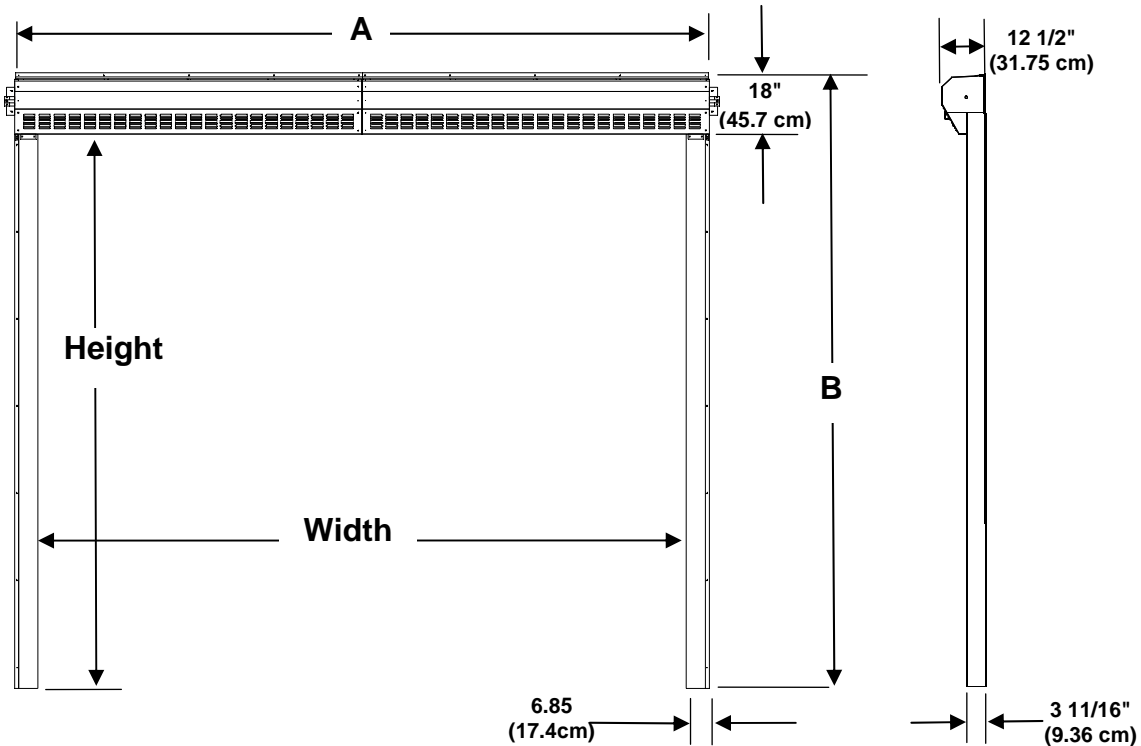

Diagram 1 – Door Dimensions and Clearances

TABLE 1 RS 400 Door Framing Dimensions:

Width Related Dimensions

RS-400 Width (Ft.)	A		
	Ft.	In.	cm
10'	11	1-3/4	340
11'	12	1-3/4	370
12'	13	1-3/4	401
13'	14	1-3/4	431
14'	15	1-3/4	462
15'	16	1-3/4	492
16'	17	1-3/4	523
17'	18	1-3/4	553
18'	19	1-3/4	584
19'	20	1-3/4	614
20'	21	1-3/4	645
21'	22	1-3/4	675
22'	23	1-3/4	706
23'	24	1-3/4	736
24'	25	1-3/4	767

Height Related Dimensions

RS-400 Height (Ft.)	B		
	Ft.	In.	cm
8'	9	6	290
9'	10	6	320
10'	11	6	351
11'	12	6	381
12'	13	6	411
14'	15	6	472
15'	16	6	501
16'	17	6	533

2. Warnings

Warning!

Disconnect All Power Sources Before Installing This Equipment. Failure To Disconnect Power Source Can Result In Property Damage, Serious Injury Or Death!

Warning!

Dangerous Rotating Machinery!
Keep Hands, Clothing, Etc. Clear When Operating!
Do Not Operate Without All Guards And Covers In Place!

Warning!

All Wiring Should Be In Accordance with National Electrical Codes Or Other Local Codes.

Warning!

The Installer Is Responsible For Complying With All Relevant Regulations, Such As National Wiring Regulations And Accident Prevention Regulations. Particular Attention Must Be Given To The Cross-sectional Areas Of Conductors, The Selection Of Fuses Or Other Protection, And Protective Earth/Ground Connections!

Warning!

The Voltages In The Power Cables And Certain Parts Of The Drive Can Result In Death. Whenever The Drive Has Been Used It Must Be Isolated And Disconnected For 5 Minutes Before Any Work Commences.

Danger!

Only Qualified Electrical Personnel Familiar With The Construction And Operation Of This Equipment And The Hazards Involved Should Install, Adjust, And/Or Service This Equipment. Read And Understand This Manual In Its Entirety Before Proceeding. Failure To Observe This Precaution Could Result In Severe Bodily Injury Or Death!

3. Limited Warranty

All products are warranted to be free from defects in material and workmanship for a period of one (1) year from the date of purchase if installed and used in strict accordance with the installation instructions. Liability is limited to the sale price of any products proved to be defective or, at manufacturer's option, to the replacement of such products upon their return. No products are to be returned to the manufacturer, until there is an inspection and/or a return-goods authorization (RGA) number is issued.

All complaints should be directed first to the authorized distributor who sold the product. If satisfaction is not obtained or the name of the distributor is not known, write the manufacturer that appears below, directed to the attention of Customer Service Manager.

This limited warranty is expressly in lieu of any and all representations and warranties expressed or implied, including any implied warranty of merchantability or fitness for a particular purpose. The remedy set forth in this limited warranty shall be the exclusive remedy available to any person. No person has authority to bind the manufacturer to any representation or warranty other than this limited warranty. The manufacturer shall not be liable for any consequential damages resulting from the use of our products or caused by any defect, failure or malfunction of our products. (Some areas do not allow the exclusion or limitation of incidental or consequential damages, so the above limitation or exclusion may not apply to you).

This warranty gives you specific legal rights and you may also have other rights that vary from area to area.

Warrantor:

RollSeal
PO Box 140
1751 County Road 68
Bremen, Alabama 35033
Phone 256-287-7000

4. Physical Description/Drawing

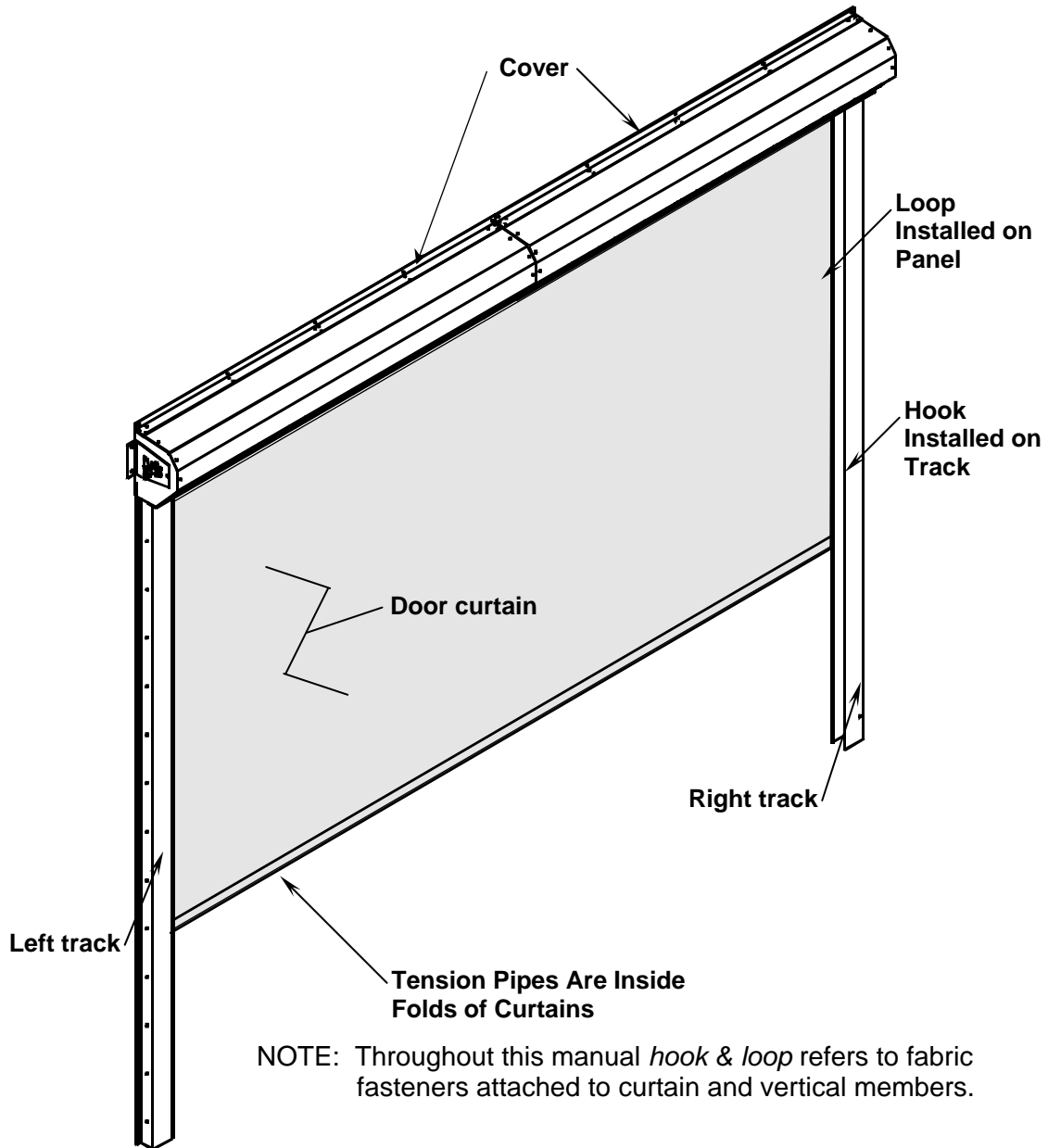

5. Installation

⚠ CAUTION!

RS 400 Door Components Are Heavy!
Before Performing Installation, Make Sure Sufficient Workers and Equipment Are Present To Lift Door Parts.

5.1 Operator Power options

- **Manual Chain Hoist**..... Power not required.
See **Section 5.6.4** for Chain Hoist installation instructions.
- **Manaras Operator Ratings:**

115 VAC	208 VAC	230 VAC	460 VAC-3ph
@ 8.0 amp	@ 2.1 amp	@ 4.0 amp	@ 1.0 amp

 See **Section 5.6.5** for Manaras Operator installation instructions.

5.2 Tools Required

Tools Required	
3/8 in. (10 mm) Power screwdriver (portable)	Socket.
3/16 in. (5 mm) Drill bit and power drill	Hammer
Carpenter's level	Tape measure
<i>NOTE: Other Tools May Be Required According To Installation</i>	

5.3 Overview

The RS 400 Door is shipped in three sections which must be assembled. The RS 400 comes with a Head Unit and panel that are preassembled in the Factory if the door/Head Unit width is 20' or less. Depending on the door/Head Unit width, if the width is over 20', the panel must be field installed. **Refer to Curtain Installation Section 5.6.6.** The part number of the Head Unit varies with the width of the Door. The Right and Left Tracks vary with the Height of the door. The Right Track and the Left Track must be attached to the Head Unit in the field. **See Diagram 2.**

The Head Unit and Tracks attach to side of the building using mounting holes pre-drilled in the Head Unit and the Tracks. The Curtain attaches to the back plate, drive pipe and top bar. Hook & Loop holds the curtain in place and seals the curtain. The Loop is laminated to the Back Plate, Drive Pipe and the Top bar.

The Floating hook is attached to the Left Track and Right Track. The Curtain is raised and lowered by a manual or motorized drive. The top covers are installed to each curtain system to enclose the drive pipe.

Please read and understand all instructions in this manual before beginning assembly and installation of your new RS 400 Door.

5.4 Adjusting the Clear Opening

Locate your particular system in Table 1, page 3. For the door size that you are installing, read overall width (A) and overall height (B) of the door. If necessary, adjust the dimensions of the mounting posts or framing members to the height and width of your particular RS 400-door system as shown in Diagram 2. Refer to **Section 5.5** for details of door attachment to framing members. Framing material must be of sufficient strength for securing screws. Make sure that mounting posts or framing members are positioned accurately so that the flanges of the vertical members align with the mounting posts or framing members.

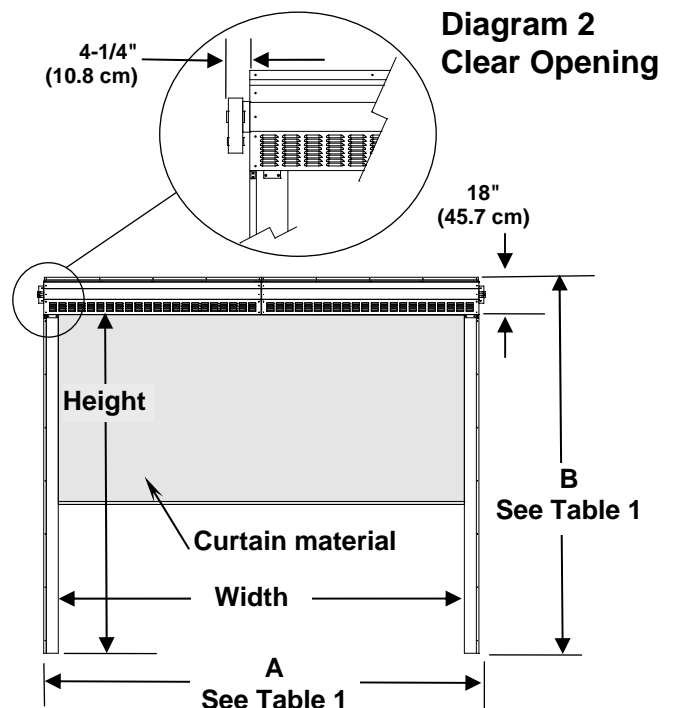

5.5 Attachment Points of Door

! CAUTION!

Framing material must be of sufficient strength for securing screws.

When sizing the clear opening for attachment of the door, pay close attention to the following guidelines. Fasteners mount through outer flanges of door to secure door in place. Flange widths are shown in Diagram 3.

1. After assembling door, make sure that door is plumb & square. See Diagram 5.
2. The Head Unit has pre-drilled holes for fastening to horizontal framing. Make sure that Head Unit will align with framing structure.
3. The vertical members attach to framing by mounting through outer flanges of vertical members. Make sure outer flanges overlap with framing structure.

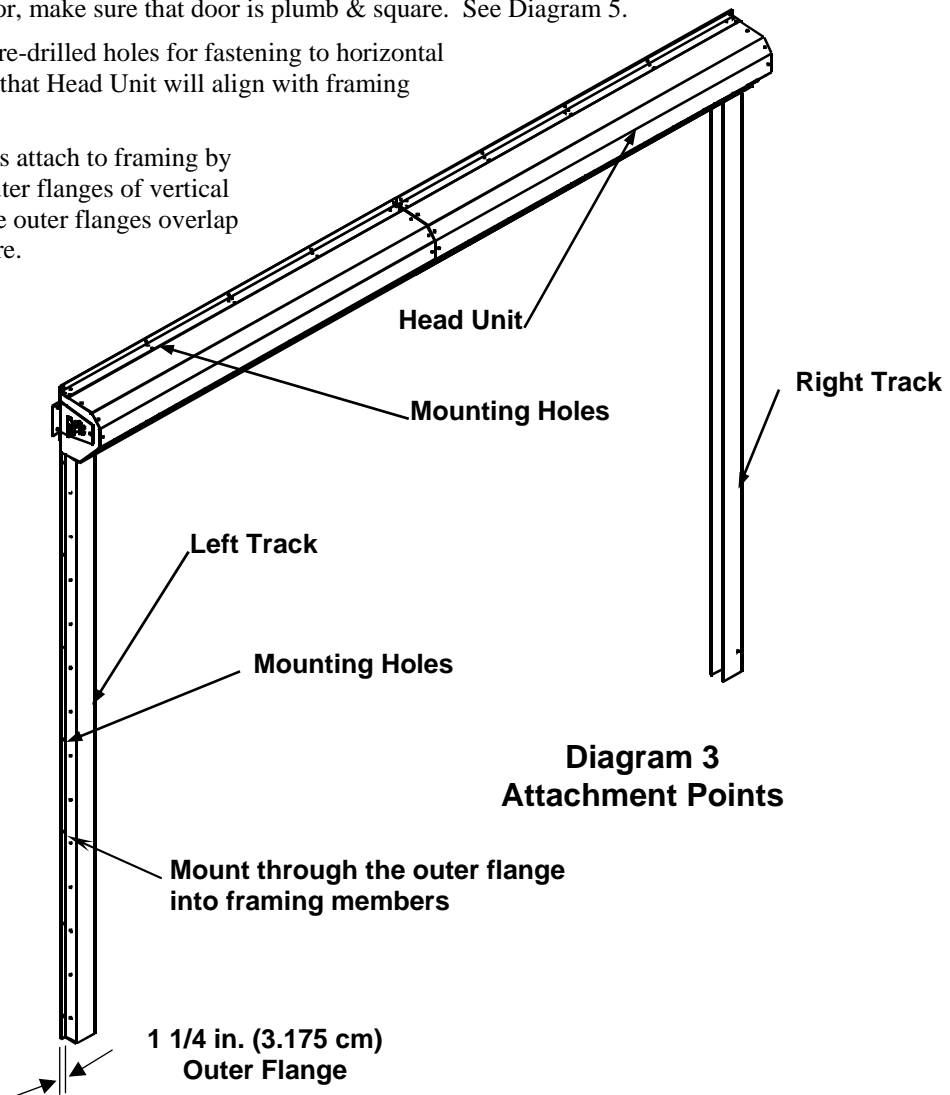

Diagram 3
Attachment Points

5.6 Assembly of Parts

5.6.1 Assembly of Head Unit and Tracks

! CAUTION!

Do not remove the Safety Brackets from the door head unit until the door is installed to the door frame and the Motor/Hoist is properly installed to the door drive shaft. See **Section 5.6.4**. Without proper support, the door will drop with rapid motion and injury may occur.

1. Arrange the horizontal member (Head Section), left vertical member (left track), and right vertical member (right track) on the floor in front of the clear opening as shown in Diagram 4 with the flange side facing upward.
2. At each end of the Horizontal member, there are two brackets. Refer to Diagram 4 shown below. One bracket attaches to threaded Pims inside the track flange. The other bracket (on the front of the head unit) attaches to threaded Pims on the outside of track unit. Attach head unit to track unit.
3. Add nuts to threaded attachment Pims. Tighten nuts securely to 90 in-lbs torque.
CAUTION: Excessive torque will damage the threaded Pims. Do not over-tighten.
4. Repeat steps 1-3 to install right track.

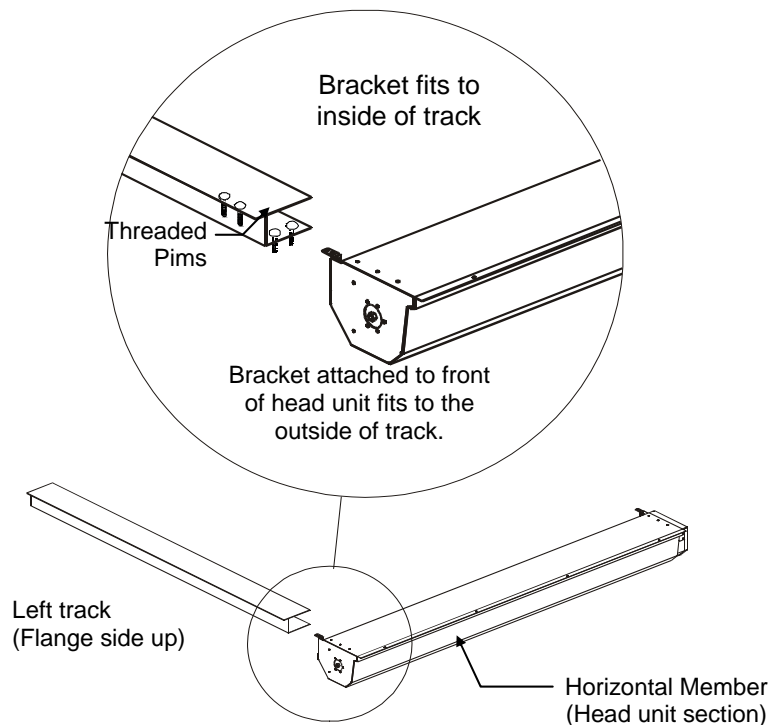

Placement of Parts for Assembly

Lay left track, right track, and head unit face down in front of the clear opening as shown.

Diagram 4 Frame Assembly

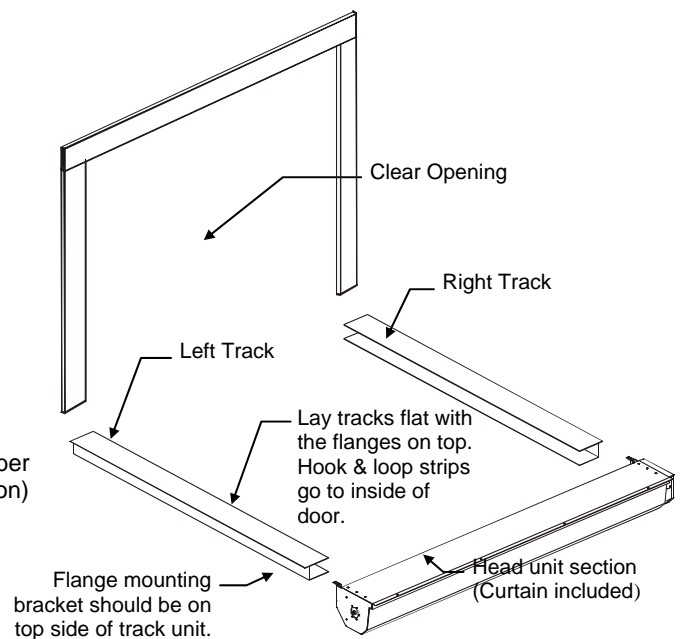

5.6.2 Fastening Door Assembly to Clear Opening

After attaching tracks to top section, the door assembly is ready for installation to the clear opening. Refer to Diagram 4 and Diagram 5.

1. Use a tape measure and make sure that the overall height and overall width of the clear opening meet the requirements: Overall Height = Door Opening Height + 12.5 in. (31.75 cm) Overall Width = Door Opening Width + 13.5 in. (34.29 cm)
2. Make sure that the door assembly is plumb and square. (Diagonal measurements, etc.)
3. Center door assembly on clear opening. Align the bottom of each vertical member with the respective framing board or posts of the clear opening.

NOTE: The vertical members should be aligned so that their outer flanges will exactly overlap with the framing boards or posts when the door assembly is raised into position.

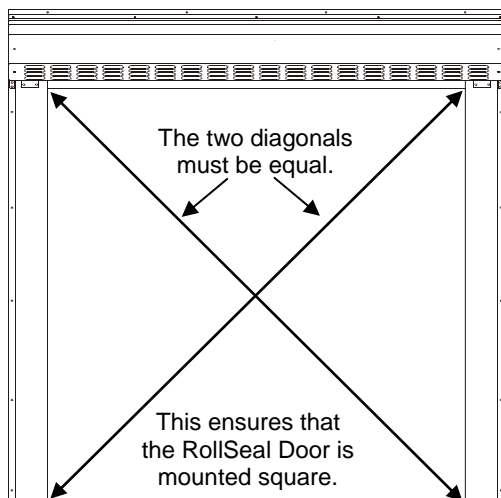
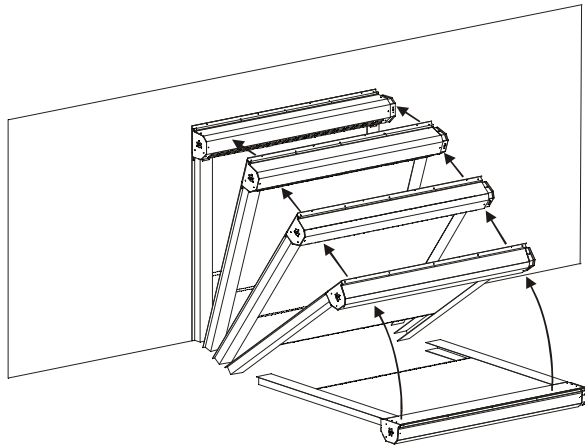

NOTE: Shift bottom of door right or left until both diagonal measurements are equal. At that point, the door is square.

4. Assemble workers and equipment into position on each side of the door assembly. **SLOWLY LIFT TOP OF DOOR ASSEMBLY TO RAISE THE DOOR.**
 5. Lean door assembly upright against clear opening.
 6. Carefully press flanges of the door assembly flush against faces of framing boards or posts. When the openings are matched, level the top and sides using a float level on the head unit, on each track, and verify the inside diagonal measurements are the same.
- IMPORTANT:** Leveling is very important because the curtain may bind if not leveled properly.
7. As shown in Diagram 5, fasten Tek screws (in steel) or lag screws (in wood) through the flanges on sides of door assembly. Securely tighten all screws.
 8. On the end bracket and upper flanges of the head unit there are attachment points for fastening screws. Fasten Tek screws (in steel) or lag screws (in wood) through the holes. This secures the top of the door to the clear opening.

NOTE: Door Widths over 20' require on-site panel installation. Refer to Section 5.6.6.

**Diagram 5
Door Assembly**

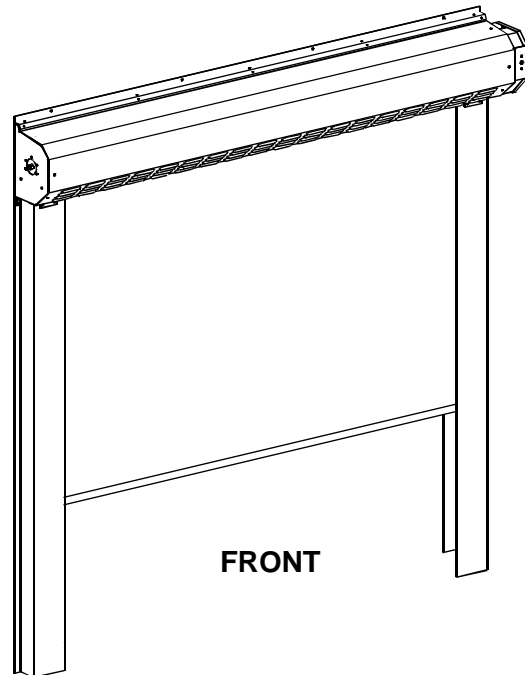

5.6.3 Safety Bracket

The Safety Bracket is designed to lock the drive shaft (during shipping and installation) to prevent injury from rapid drop of the door curtain. A Safety Bracket is installed on each end of the head unit. Removal of the bracket should only be done after door is secured to structure.

! CAUTION!

Only remove the Safety Bracket from the side of the door that gets the hoist or motor, once door is secured to wall. The Safety Bracket on the opposite side can only be removed after the motor or hoist is installed. ***Removal of both Safety Brackets without motor or hoist installed can cause serious injury or damage.***

Removal of First Safety Bracket:

1. Remove cable tie and tag. Not shown below.
2. Remove the shaft locking hardware. See Detail B Item 1.
2. Remove the two bolts holding Safety Bracket to Head Unit. See Detail B, Item 2.
3. Retain hardware and bracket for later use.

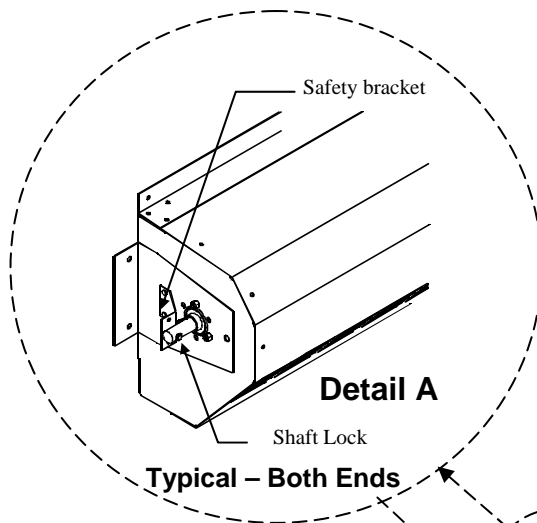

**Diagram 6
Safety Bracket**

Head Unit
(Track and Structure not shown)

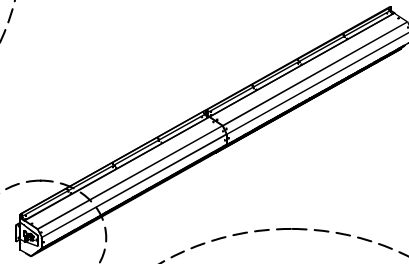

Removal of Second Safety Bracket:

1. Motor or Hoist is installed.
2. Repeat steps 1-4 from above.

NOTE: Cable tie and tag not shown

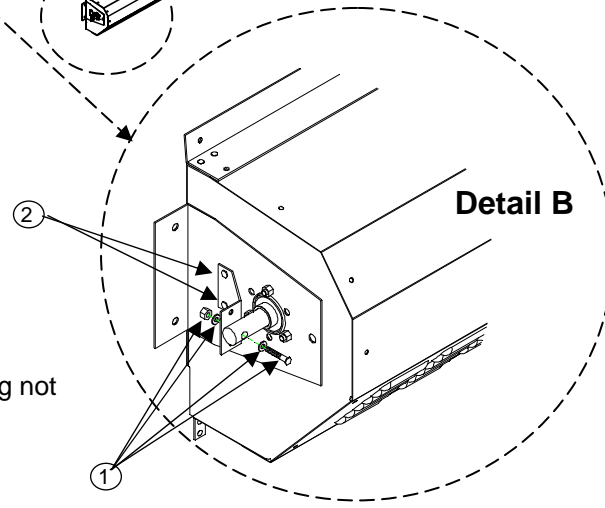

Safety Bracket Removal

5.6.4 Chain Hoist Installation

Chain Hoist can be installed on left or right side of door.

1. Remove the Safety Bracket only on the side of the door where the hoist is to be installed. Retain bracket and hardware for later use. See **Section 5.6.3**.
2. On shaft end of door, position U-shaped mounting bracket (6421-9393) over shaft.
3. Align bolt holes of bracket with attachment holes in door.
4. Insert bolts through cut-out openings of mounting bracket.
5. Securely attach mounting bracket to door.
6. Position Chain Hoist (6421-9339) onto mounting bracket. Align bolt holes of Chain Hoist with holes in mounting bracket.
7. Securely fasten Chain Hoist to bracket with bolts provided.
8. Securely attach Catch Bracket to wall with self-tapping screws provided.
9. Securely hook chain into Catch Bracket as shown below.
10. Remove the Safety Bracket on the opposite side of the door from the hoist. Retain bracket and hardware for later use. See **Section 5.6.3**.
11. Hoist installation complete. See **Section 6** for Door Operation.

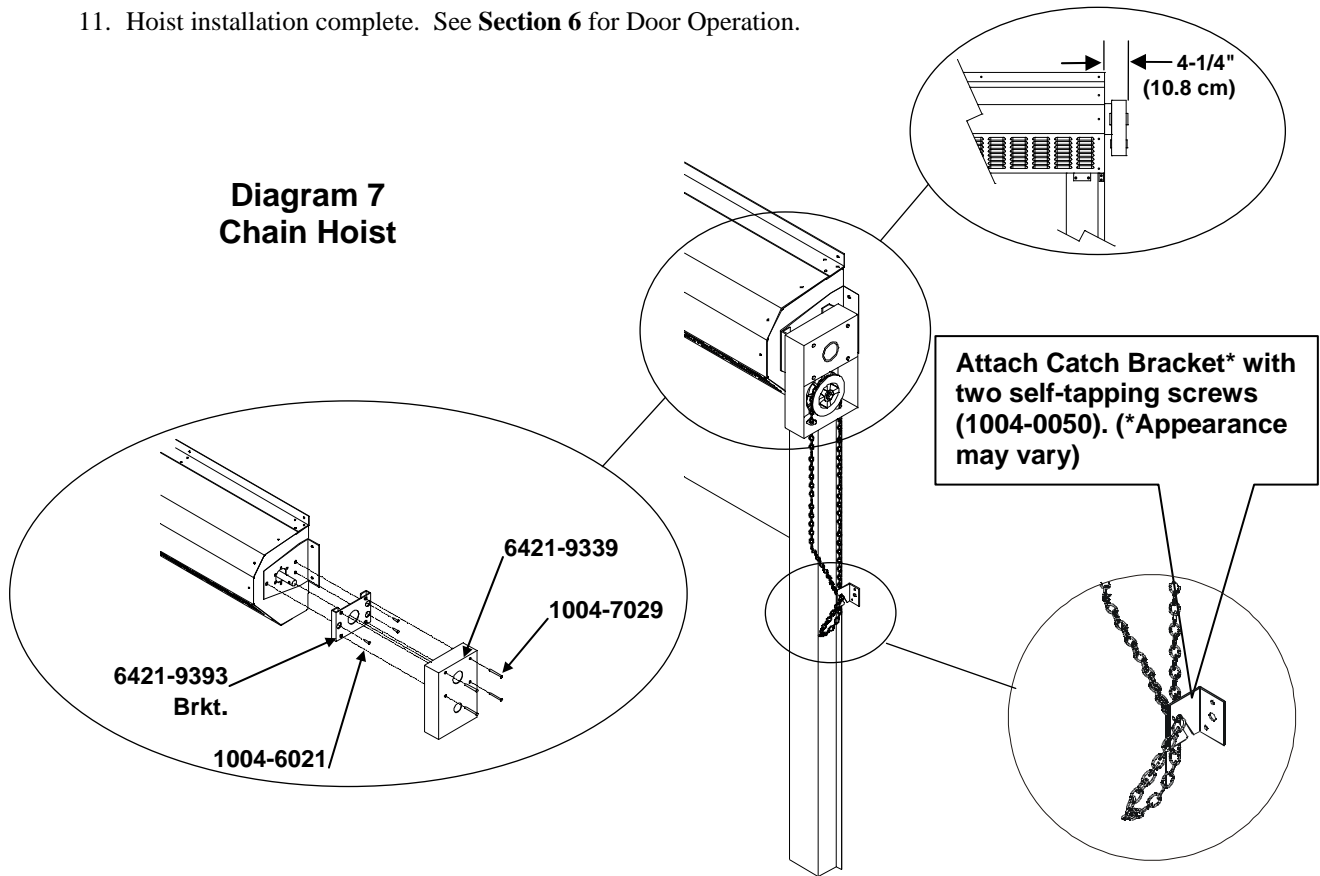

Warning!

NEVER RELEASE CHAIN!

If Chain Is Released, Door Will Drop With Rapid Motion. Injury May Occur If Chain Is Released!

5.6.5 Manaras Operator

IMPORTANT NOTES:

1. This Operator Must Be Installed A Minimum Of 8 ft. (2.4m) Above Floor.
2. Remove the Safety Bracket only on the side of the door where the motor is to be installed. Retain bracket and hardware for later use.
3. Verify that framing is structurally sound for mounting motor.

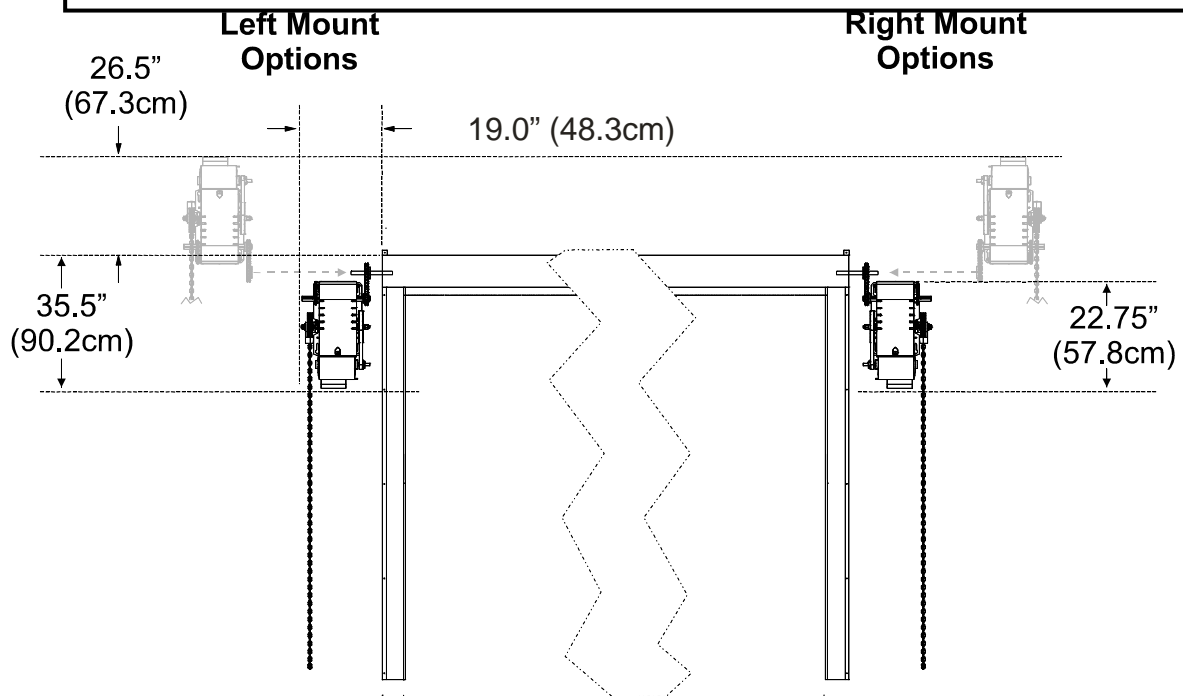

NOTE: Dimensions are approximate.

5.6.5.1 Installation of Manaras Operator

The Manaras Operator has two sets of mounting holes: outside the frame for wall mounting and inside the frame for hood mounting. To open the control box cover, loosen the screw at the base of the cover. If the cover cannot be fully opened, the retaining cam may be used to hold the cover in other positions. See the following Figure, *Control Box Cover Opening*

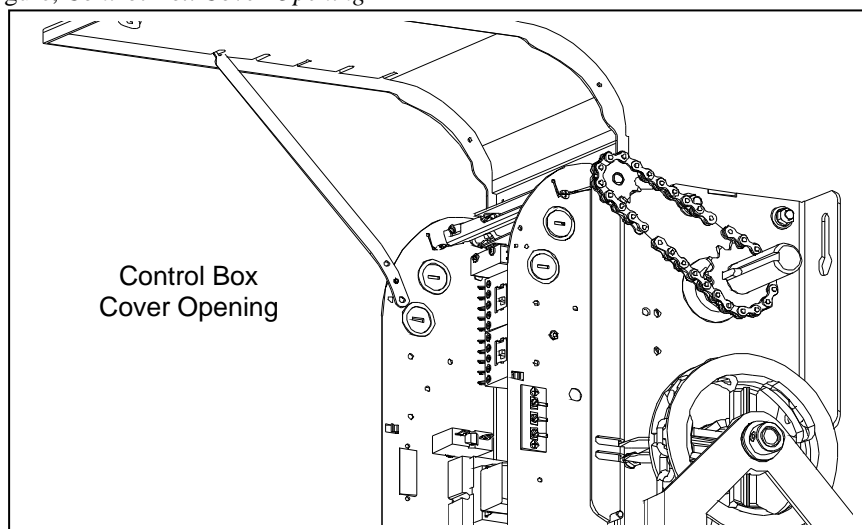

After installation, verify that there is no obstacle in the way when opening the control box cover. If an obstacle exists preventing the cover from opening, it is possible to remove the cover by cutting the plastic hinge at its thinnest point or unscrewing it from the box before putting the operator on the wall or hood. Closing the cover will also require using two supplementary screws. See the following Figure, *Hinge Elimination And Cover Fastening By Screws*.

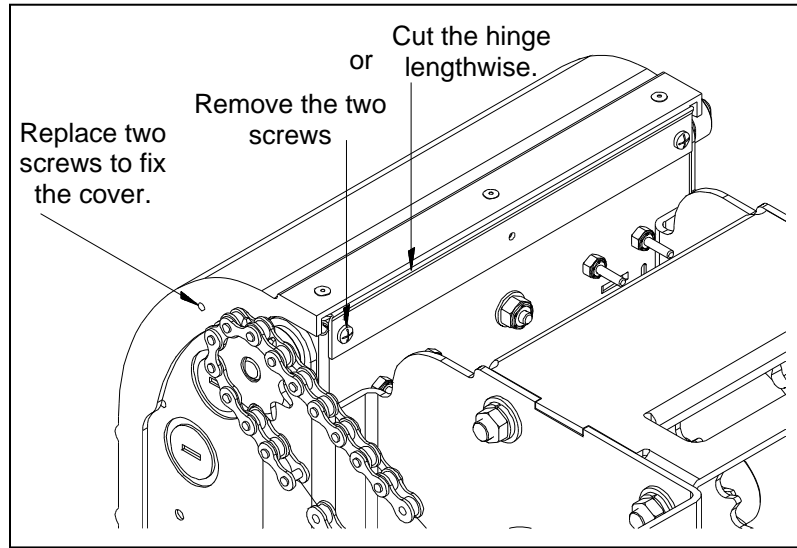

Hinge Elimination And Cover Fastening By Screws

5.6.5.2 Mounting the Manaras Operator

Locate the four mounting holes. The optimum distance between the door shaft and operator drive shaft is between 12" and 15". Mount the OPERA unit by fastening it to the wall, bench or hood with 3/8" or 1/2" thru-bolts or if the wall is of such construction so as to prohibit use of thru-bolts, lag bolts and shields of sufficient size may be used. **Do not tighten.** See the following Figure, *Mounting Dimensions For Wall Or Hood*.

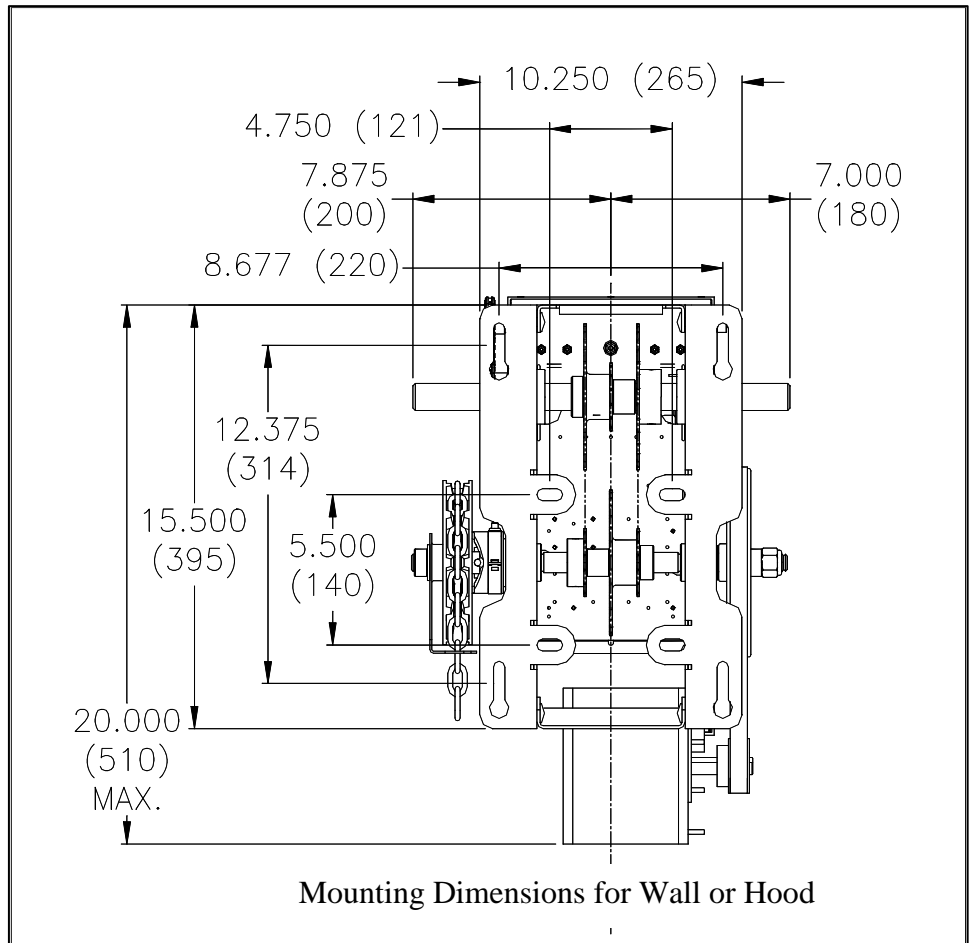

Mounting Dimensions for Wall or Hood

5.6.5.3 Spreader, Sprocket, and Chain Installation

CAUTION!

MAKE CERTAIN THAT THE OPERATOR IS PERFECTLY ALIGNED WITH DOOR SHAFT, OTHERWISE, DAMAGE CAN OCCUR.

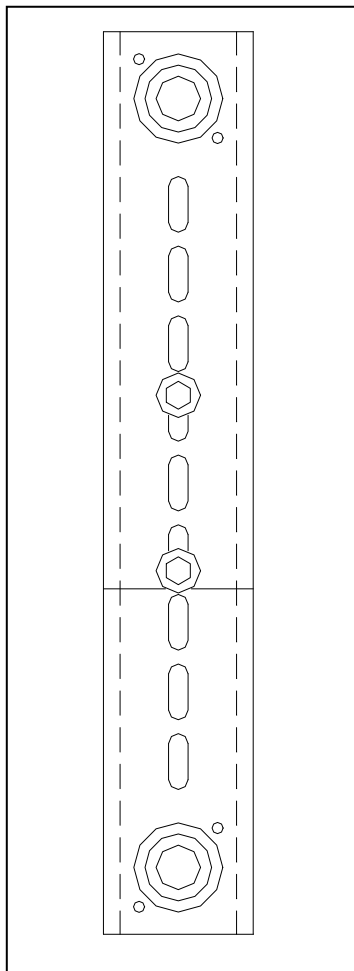

Mounting Chain Spreader

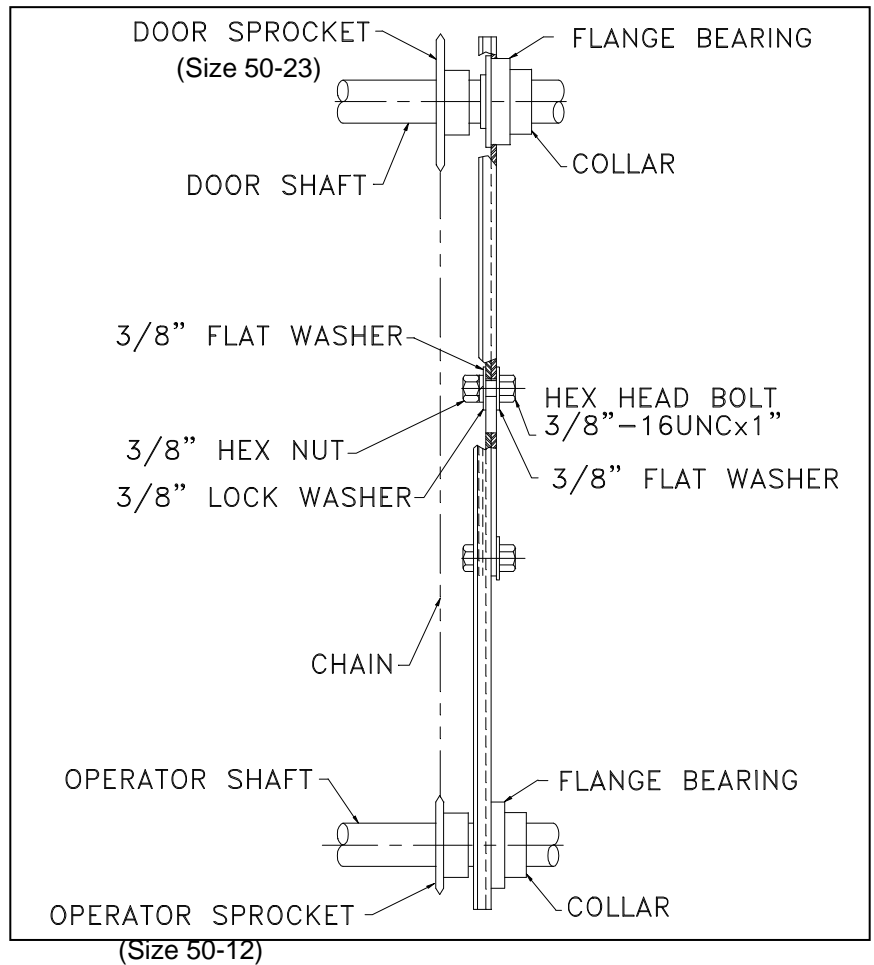

Chain Spreader Mounted On Door And Operator Shafts.

NOTE: If a chain spreader has been ordered along with your operator, refer to Figure, *Mounting Chain Spreader* and Figure, *Chain Spreader Mounted On Door And Operator Shafts* for installation.

1. Place the driven (Size 50-12) sprocket on the door shaft loosely and align it with the drive (Size 50-23) sprocket of the Manaras operator.
2. Lock the drive and driven sprockets in place by inserting the keys and tightening their respective set screws.
3. Connect the sprockets with the drive chain, shorten to a suitable length and join together with the chain link provided in the hardware bag. To shorten the chain, punch out the pin that will leave an

inside link nearest to the desired length. Connect the chain around the sprockets using the chain link. Refer to the following Figure, *Chain Link*.

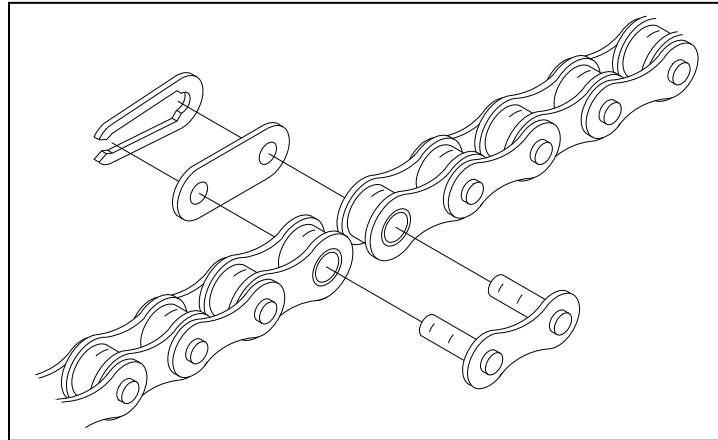

Chain Link

4. Slide the operator to tighten the drive chain and then firmly tighten the mounting bolts. Check the tension on the chain and the set screws on the sprockets (there should be no more than 1/4" slack when chain is depressed between sprockets).
5. Opera-MH: Run hand chain through the pocket wheel and through the chain guide outside the frame (Refer to the following Figure, *Installing Hand Chain On Manaras Operator*), allow both ends to hang down toward the ground and cut hand chain, if necessary, so that both ends are approximately 2 feet (0.6 m) from floor. Connect both ends of hand chain.

CAUTION!

BEFORE PULLING HAND CHAIN THROUGH POCKET WHEEL OR LIFTING THE DOOR DIRECTLY BY HAND, PULL CAM PLATE AND SPIN CAM NUTS TO CENTER OF LIMIT SHAFT SO AS TO BE SURE THE CAMS ARE NOT BEING MECHANICALLY DRIVEN THROUGH THEIR NORMAL LIMIT SWITCH END POSITIONS.

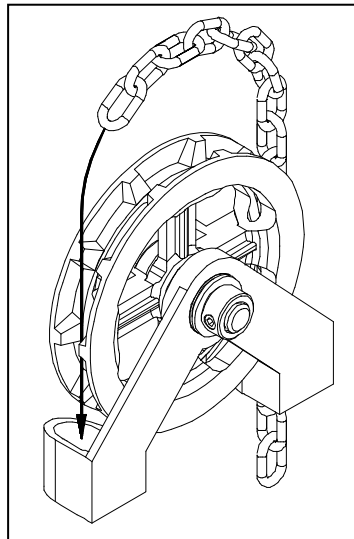

Installing Hand Chain on Manaras Operator

5.6.5.4 Limit Switches

Warning!

TO AVOID THE DANGER OF POSSIBLE DAMAGE TO THE DOOR AND OPERATOR, TRAVELLING CAMS MUST BE ADJUSTED TO THEIR APPROXIMATE POSITIONS BEFORE MANUALLY OPERATING THE DOOR OR BEFORE APPLYING POWER TO THE OPERATOR.

There are 4 limit switches. Two are used as end of travel, one is for radio-control or one-button operation and one is for reversing devices. These switches are activated by the rotary cams traveling on a threaded shaft. Refer to the following Figure, *Limit Switches*.

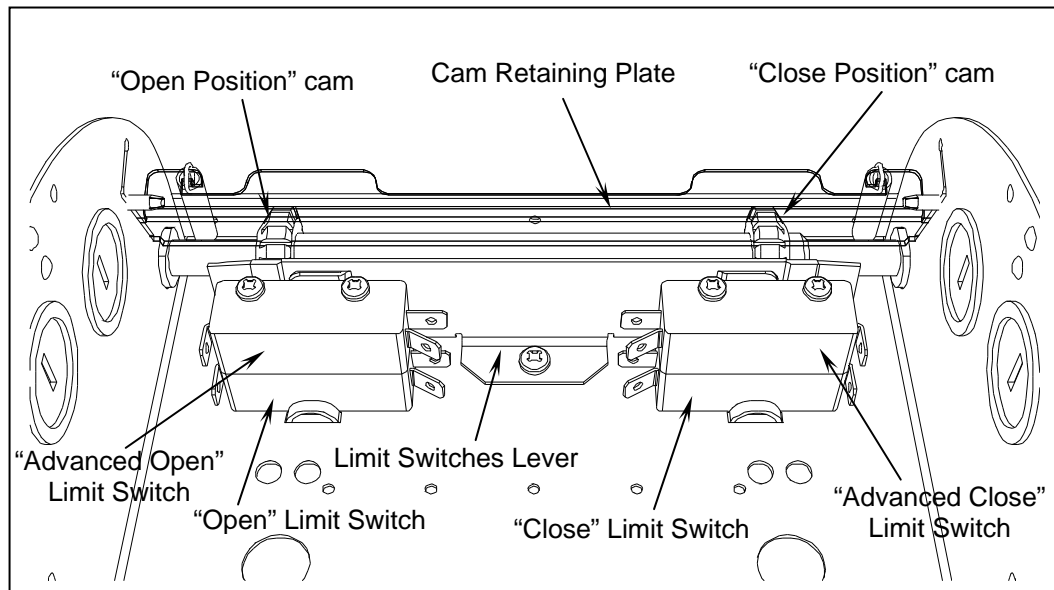

Limit Switches

5.6.5.5 Adjustment of Limit Switches

Warning!

NEVER PLACE HANDS OR TOOLS INSIDE OPERATOR OR NEAR DRIVE MECHANISM UNLESS POWER IS OFF.

Warning!

Do not remove the Safety Brackets from the door head unit until the door is installed to the door frame and the Manaras Operator is properly installed to the door drive shaft. Without proper support, the door will drop with rapid motion and injury may occur.

Before using the Manaras Operator's UP/DOWN manual chain or switch controls, ensure the Safety Brackets are removed from the door head unit.

1. Open the cover of the electrical enclosure.
2. Manually raise the door to a nearly opened position using the Manaras manual chain. (Refer to Section 6.3, Manual Operation of Door with Manaras Operator)
3. Pull the traveling cam retaining bracket on the Open Position cam side and rotate the Open Position cam. Refer to Figure 'Adjusting the Limit Cams' in this section.)
4. Manually rotate the Open Position cam until the lever activates the Open limit switch sufficiently so as to hear the switch click.
5. Release and engage the retaining bracket. Make sure that the bracket engages in the slots of both limit cams after each adjustment.
6. Manually lower the door to a nearly closed position and repeat steps 3 through 5 with the Close Position cam.
7. Upon completion of all wiring connections (Section 5.6.5.9), repeat steps 2 through 6 of Section 5.6.5.5 using the "Stop" button for adjustments of limit switches to their final, exact positions.

Note: Turning the cam towards the center of the shaft increases door travel. Turning the cam towards the switch decreases door travel.

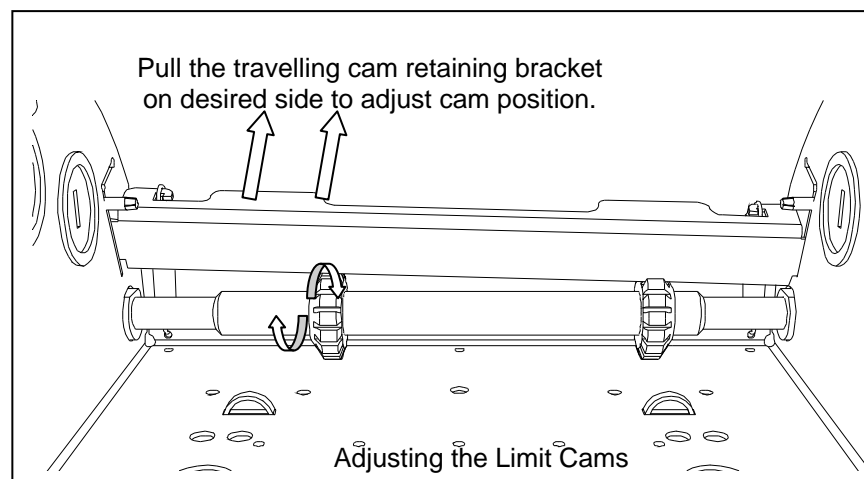

5.6.5.6 Minimum Suggested Wire Size for Control Circuit

The control circuit operates at 24 VAC. Due to the resistance in the wire used to carry the control circuit voltage, it is important to use the appropriate wire size with respect to the distance between the operator and the push-button station.

Below is a chart, "24 VAC CONTROL WIRING", indicating the minimum recommended wire size with respect to the total distance between the operator and the push-button station. DO NOT exceed the maximum distance. If there are several push-button stations in series you must ADD all these distances before selecting the appropriate wire gauge for your operator.

If the wire gauge is not suitable for the distance, problems in operation will be encountered such as chattering relays and contactor, premature wear of the contacts and possible tripping of the motor's thermal protection. If a greater distance is required, a long distance interface module is suggested (consult the manufacturer).

When large gauge wire is used, a separate junction box will be needed for operator power connection.

All power wiring to the operator should be installed by a qualified electrician and may vary with respect to conduit size and type as specified in the National Electrical Code, Article 430, allowing 5% voltage drop. Power must also be connected in accordance with local codes.

24 VAC CONTROL WIRING	
Minimum suggested Wire gauge (AWG)	Maximum distance between operator and all Push-button stations feet (meters)
22	50 (15)
20	100 (30)
18	150 (45)
16	250 (75)
14	350 (105)
12	450 (135)

5.6.5.7 Wiring of the Manaras Operator

Do NOT connect any accessory controls until the limit switch adjustments have been completed and the operator is functioning properly. Refer to the Manaras Installation and Instruction Manual. Wiring diagrams are found inside the control box cover.



Warning!

EXERCISE CAUTION WHEN OPERATING MACHINE. THE DRIVE CHAIN AND LIMIT CHAIN, WHEN EXPOSED AND TURNING, COULD CAUSE SEVERE INJURY.

5.6.5.8 Main Power Supply

Power to the operator is of the permanent connection type. Connect according to local electrical code. Ground the unit using the ground lug inside the control box.

IMPORTANT: Be aware of the dimension of the power supply cables pipe (BX for ex.) It must not limit the control box movement to access the mechanical reduction parts. It is recommended to **add 7 or 8 inches**.

For single phase operators, connect the power supply to terminals L (line) and N (neutral) on the main terminal strip as shown in the following diagram.

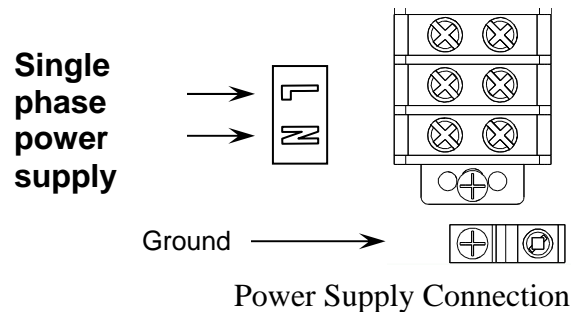



Warning!

GROUND THE UNIT CORRECTLY USING THE COPPER GROUND LUG LOCATED INSIDE THE OPERATOR CONTROL BOX.

Note: All other connections on the terminal strip (1 to 9) are low voltage class II 24 VAC.

1. External interlock between terminals 1 and 2. A jumper is factory installed between these two terminals. If an external interlock is used (such as interlocking between two doors), remove the jumper between 1 and 2 and wire the interlock between these two terminals. See the following diagram.

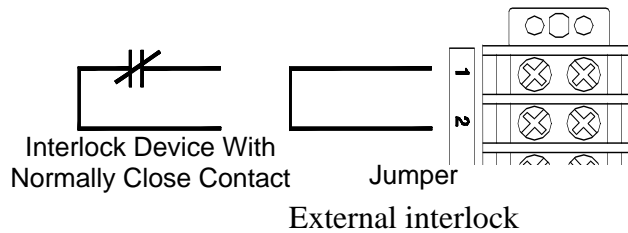

2. A 3 button push-button station (open/close/stop) can be wired to terminals 2, 3, 4 and 5. Two push-button stations can be wired to these same terminals by following the wiring diagrams found inside the Manaras control box cover.

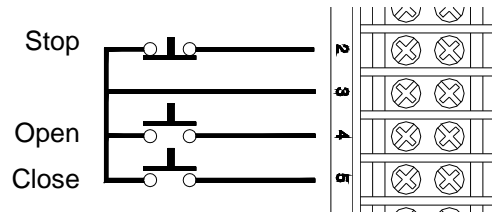

Three button push-button station

3. Three terminals are provided for the wiring of a radio-control receiver. Terminal #9 is Ground, #7 is 24 VAC (common) and #8 is the relay contact provided by the radio-control receiver to activate the door to open or close. Furthermore, terminals 7, 8 and 9 are doubly available on the terminal strip inside and on a separate small terminal strip located on the side of the unit. This terminal makes it convenient to wire-up a standard single button radio receiver on the side of the unit. When the transmitter is activated, the door will open to the fully open position. From the fully open position, the door will close. If transmitter is activated while closing, the door will reverse to the fully open position.

NOTE: It may be required to reverse connections to 7 and 9 for other types or radio receivers (Allstar, Linear, Pulsar ...).

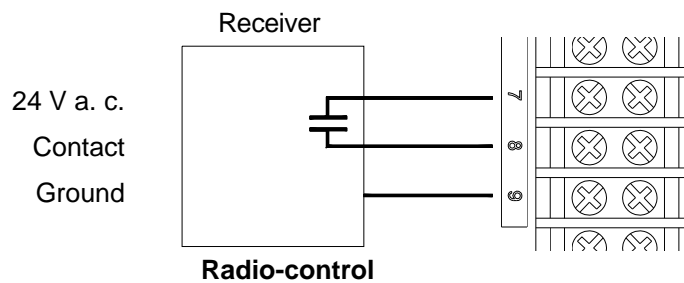

Radio-control

4. A single button open/close door device can be wired to terminals 7 and 8 to behave in the same way as the radio control receiver.

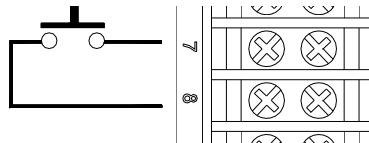

Single button device

NOTE: If several control devices are to be used, connect one and check for proper operation before connecting the next device.

5. A reversing edge can be wired up to terminals 3 and 6 (see also **Section 5.6.5.9**). These terminals can also be used for any other reversing devices such as loop detectors and photocells.

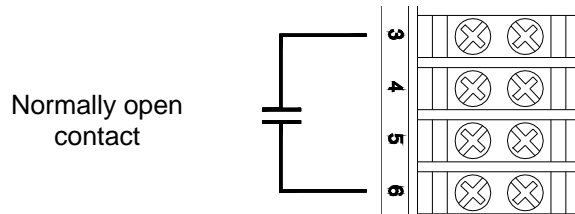

Reversing edge or other device

IMPORTANT: Upon completion of all wiring connections, readjust limits as mentioned in **Section 5.6.5.5** using "Open", "Close" and "Stop" buttons.

5.6.5.9 Wiring Options to the Manaras Operator Terminal Block

- **Radio Controls:** Consists of a radio receiver unit and remote transmitters. These controls consist of an RF signal being emitted on a "pulse" basis to a mated receiver tuned to the same "pulse" rate. Once the receiver accepts the code, a relay is activated closing a set of contacts.
- **Photo-electric units:** Can be used as opening and reversing devices. An infra red light is emitted from the control to a reflector and back. If, during closing travel of the door, the light beam is broken, the door will reverse to the fully open position.
- **Digital Keypad:** Consists of a control head which is pedestal mounted. Similar to a telephone touch pad it allows the selective coding of a four number series. Once the programmed series of numbers is received in their set order, a relay closes and completes a circuit.
- **Card Reader:** A magnetic-mechanical device which accepts sealed and coded cards. The cards trigger magnets to raise in the cartridge head, releasing a lock mechanism which allows a deeper insertion of the card. The card then contacts a switch that closes the circuit.
- **Key Switch:** Momentary contact will open door. Can be wall or post mounted for interior or exterior use.

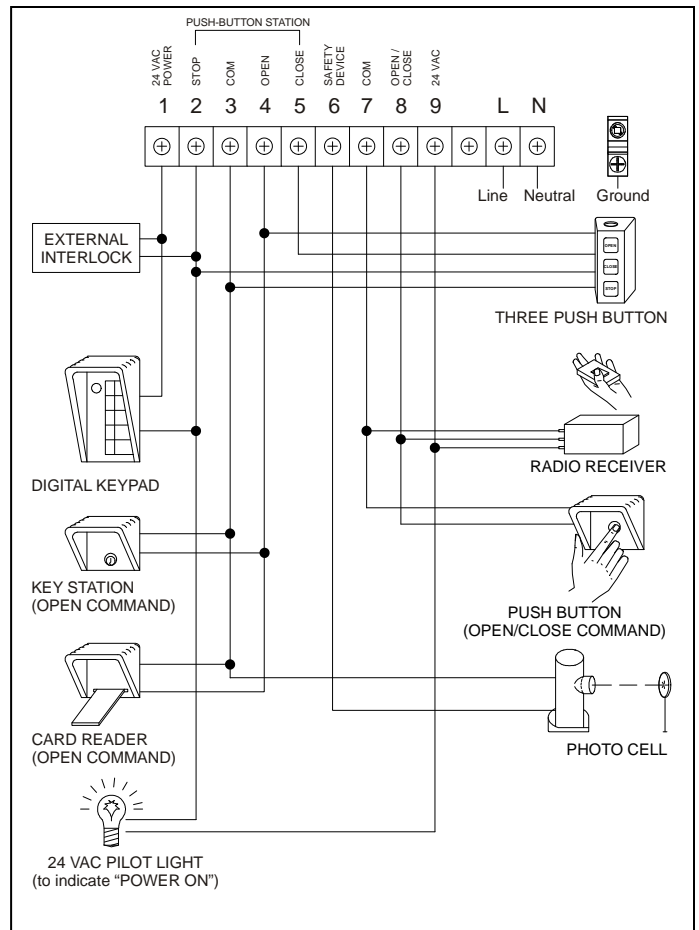

Manaras Terminal Input Connections

* Refer to the Figure, *Manaras Terminal Input Connections*.

NOTE: Certain accessory devices may require additional power wiring.

5.6.6 Curtain Installation

NOTE: Door Widths over 20' require on-site panel installation.

1. Remove Horizontal Member covers shown in **Section 5.6.8**.
2. After roller is in place, install the curtain material. The door curtain consists of three curtains that are sewn together. The curtains can be identified by the following descriptions (See diagram below):

Center Curtain: The center curtain has a hook strip across the top of curtain only. This curtain attaches to the loop on roller.

Inside Curtain: The inside curtain has hook strips at top and down each side of the curtain. This curtain is shorter than the inside curtain. This curtain attaches to the loop on backplate.

Outside Curtain: The outside curtain has hook strips at top and down each side of the curtain. This curtain is longer than the inside curtain. This curtain attaches to the top bar.

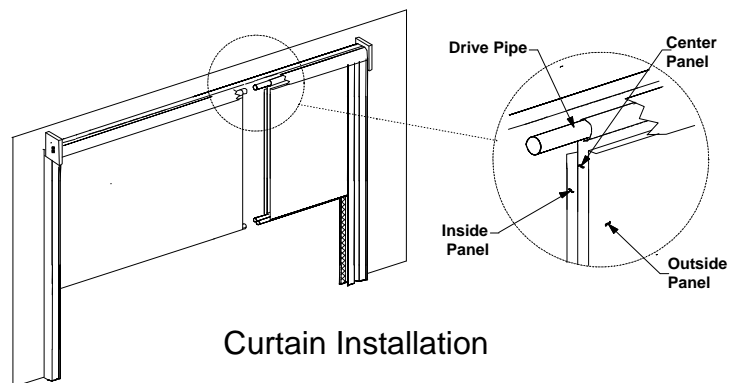

Curtain Installation

2. Attach the inside curtain to backplate. The hook strip at the top of the curtain sticks to the loop strip of the backplate. Align top & ends of curtain even with top & ends of backplate. Press the hook & loop strips together along the entire backplate.
3. After the inside curtain has been attached, attach center curtain to the roller. The center curtain wraps around the roller from the inside (between the backplate & roller). Attach hook & loop strips of roller & center curtain. Press strips together along the entire roller. NOTE: Make sure to install curtain straight along entire length of roller.
4. Attach outside curtain to top bar. Insert curtain from back of top bar. Firmly press together hook & loop strips of top bar and outside curtain.
5. After curtain has been secured, install tension pipes inside folds of curtain as shown in the diagram in **Section 5.6.7**.
6. Proceed to **Section 5.6.7** to adjust the curtain.

5.6.7 Door Curtain Adjustments

During normal operation, the tension pipes should run in close proximity of each other. The clearance between the tension pipes should normally be between 1/4" to 1/2" (6.35 mm - 12.7 mm). There are two situations pertaining to the tension pipes that may cause problems with door operation. If the tension pipes are too far apart, the tension pipes will not repel each other. This causes poor contact between the hook & loop. On the other hand, if the tension pipes are riding one another (i.e. touching one another), the door curtain material does not flow evenly, thus leaving wrinkles in the curtain instead of a stretched, smooth & even appearance.

Adjustment Procedures

The clearance between the tension pipes can be adjusted by raising or lowering the door curtains. Each door has three curtains: (1) The inside curtain (curtain facing the inside of building) is attached to the backplate. (2) The center curtain is attached to the roller. (3) The outside curtain (facing the outside of building) is attached to the top bar. Adjustments are made to the inside curtain and/or the outside curtain.

To adjust the height of the outside tension pipe, raise or lower the outside door curtain by detaching the curtain hook & loop from the top bar, and raising or lowering the curtain. Then re-attach the curtain loop to the hook on the top bar. Be sure to keep tension pipe level during this procedure. Install tek screws through the curtain material and into the top bar to securely hold the material in place. See the diagram below.

To adjust the height of the inside tension pipe, raise or lower the inside door curtain by detaching the curtain hook & loop from the backplate, and raising or lowering curtain. Then re-attach the curtain loop to the hook on backplate. Be sure to keep tension pipe level during this procedure. Install tek screws through the curtain material and into the backplate to securely hold the material in place. See the diagram below.

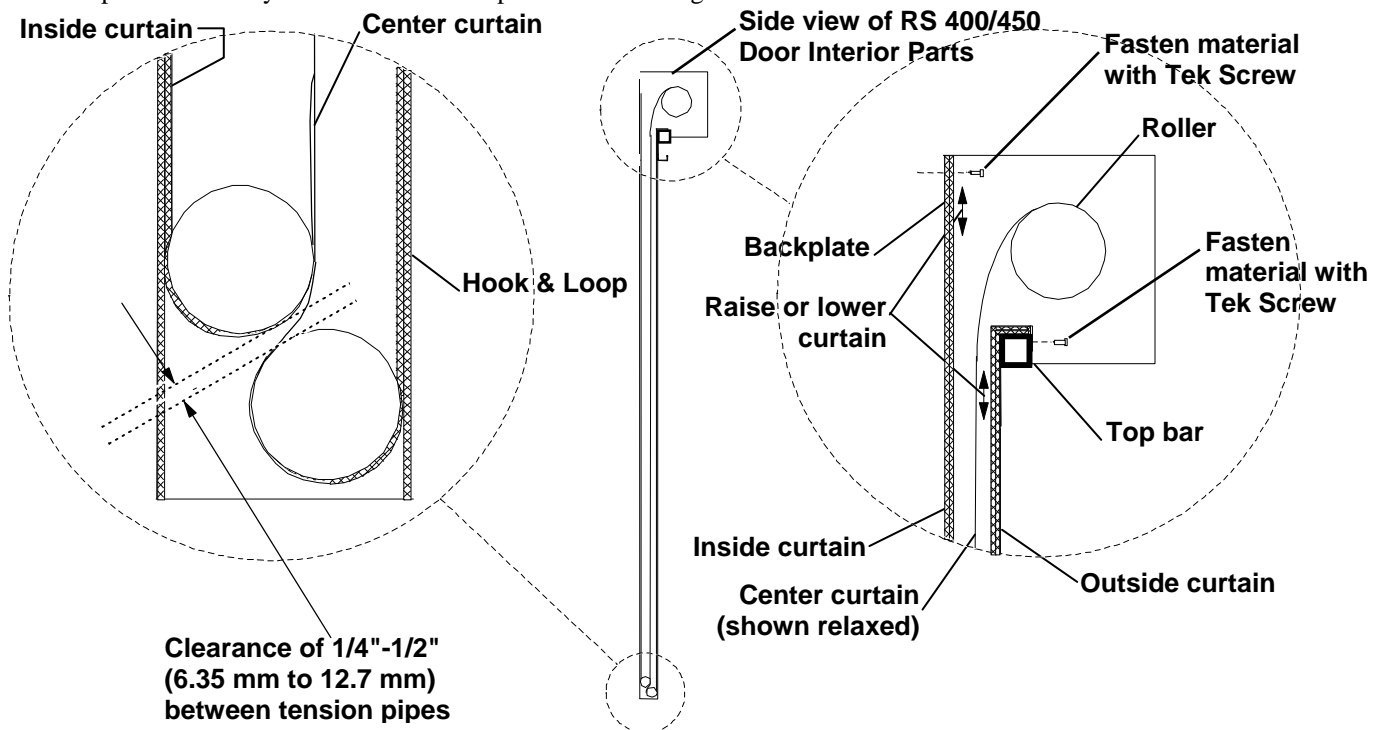

5.6.8 Install Horizontal Member Covers

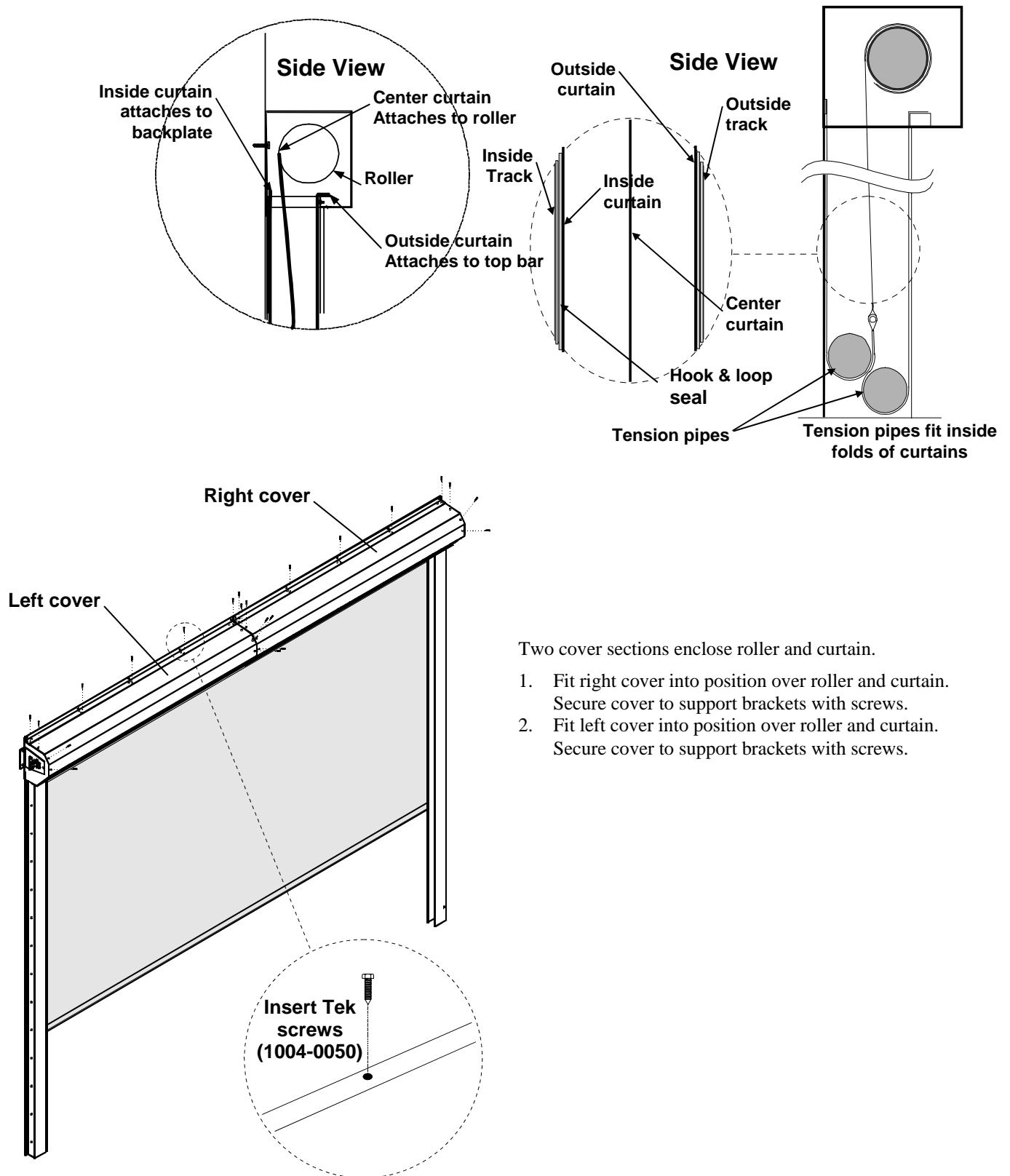

Two cover sections enclose roller and curtain.

1. Fit right cover into position over roller and curtain. Secure cover to support brackets with screws.
2. Fit left cover into position over roller and curtain. Secure cover to support brackets with screws.

6. Operation of Door

Before normal door operation can begin, door must be tested to ensure door is installed and functioning correctly. To test the door, open and close the door (See **Sections 6.1, 6.2 and 6.3**) a few times to test door operation and remove any wrinkles in the door curtain. Test all options you have installed on door. If you detect any problems, STOP. Disconnect electrical power, if applicable. Contact your distributor for assistance.

After door testing is complete, remove two 18" Velcro strips (1 Front, 1 Back) from top of each Left and Right Track Assembly. See diagram at right.

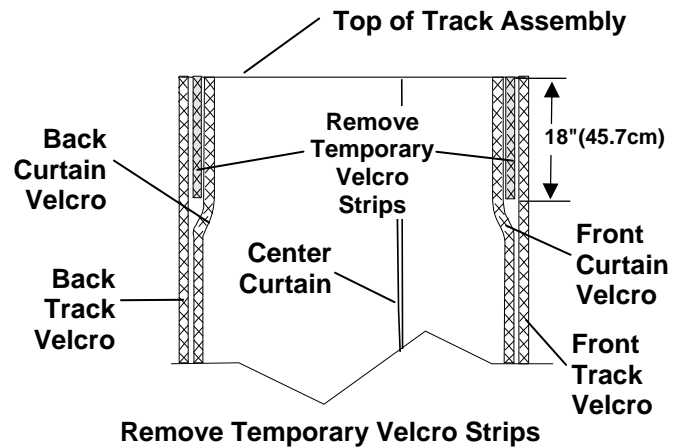

6.1 Manual Operation with Chain Hoist

1. Carefully pull chain to Open (Raise) door. CAUTION! Never release chain while door is being raised or lowered.
2. When door is fully raised, securely hook chain into Catch bracket as shown in Chain Hoist Instructions.
3. To Close (Lower) door, **securely hold chain**. Unhook chain from bracket. Gradually close door. **IMPORTANT:** You must maintain tension on chain while door is lowered to prevent rapid drop (closing) of the door.

6.2 Switch Operation with Manaras Operator

Complete installation and operating instructions are provided with the Manaras Operator at the time of delivery. Refer to these instructions for the proper installation and alignment of the Manaras operator.

To Operate Door:

1. Depress manual control button. Door curtain will unroll to 'closed' position.
2. Depress manual control button. Door curtain will roll up to 'open' position.
3. Depress button to open or close door as desired.

6.3 Manual Operation with Manaras Operator

The RS 400 door can be operated manually in the event of a power outage or if there is a motor malfunction. To operate the door manually, perform the following instructions.

Warning!

Do not attempt to manually operate the door while the operator is running. Do not attempt to manually force a malfunctioning door to open or close. The chain is an emergency device and is not designed to operate a door with serious mechanical problems.

1. Pull on the hand chain in the down direction. The first foot pulled will engage the chain hoist mechanism and disable the electrical circuit.
2. Continue to pull the chain in the desired direction. Repeat actions 1 and 2 in the opposite direction if the door does not run in the desired direction.
3. To return to electrical operation, pull slightly on the chain in the opposite direction.
5. Adjustment of the door is required if no door movement occurs after two feet of pulled chain. To adjust, turn the adjusting nut clockwise (**See Figure, Chain Adjusting Nut**) by $\frac{1}{4}$ turn until the hoist engages after pulling one foot of chain.

NOTE: If the nut is too tight, the manual torque on the chain will be too heavy.)

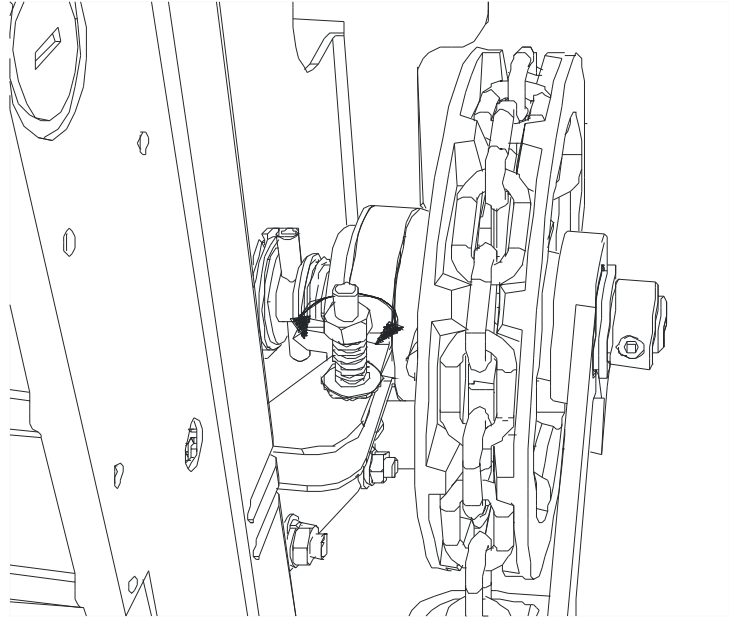

Chain Adjusting Nut

7. Adjustment Procedures

During normal operation, the tension pipes should run in close proximity of each other. The clearance between the tension pipes should normally be between 1/4" to 1/2" (6.35 mm - 12.7 mm). There are two situations pertaining to the tension pipes that may cause problems with door operation. If the tension pipes are too far apart, the tension pipes will not repel each other. This causes poor contact between the hook & loop. On the other hand, if the tension pipes are riding one another (i.e. touching one another), the door curtain material does not flow evenly, thus leaving wrinkles in the curtain instead of a stretched, smooth and even appearance.

The clearance between the tension pipes can be adjusted by raising or lowering the door curtains. Each door has three curtains: (1) The inside curtain (curtain facing the inside of building) is attached to the back plate. (2) The center curtain is attached to the drive pipe. (3) The outside curtain (facing the outside of building) is attached to the top bar. Adjustments are made to the inside curtain and/or the outside curtain.

To adjust the height of the outside tension pipe, raise or lower the outside door curtain by detaching the curtain from the top bar, and raising or lowering the curtain. Then re-attach the curtain loop to the hook on the top bar. Be sure to keep tension pipe level during this procedure. Install pan head screws through the curtain and into the top bar to securely hold the material in place. See the diagram below.

To adjust the height of the inside tension pipe, raise or lower the inside door curtain by detaching the curtain from the back plate, and raising or lowering curtain. Then re-attach the curtain loop to the hook on back plate. Be sure to keep tension pipe level during this procedure. Install pan head screws through the curtain and into the back plate to securely hold the material in place. See the diagram below.

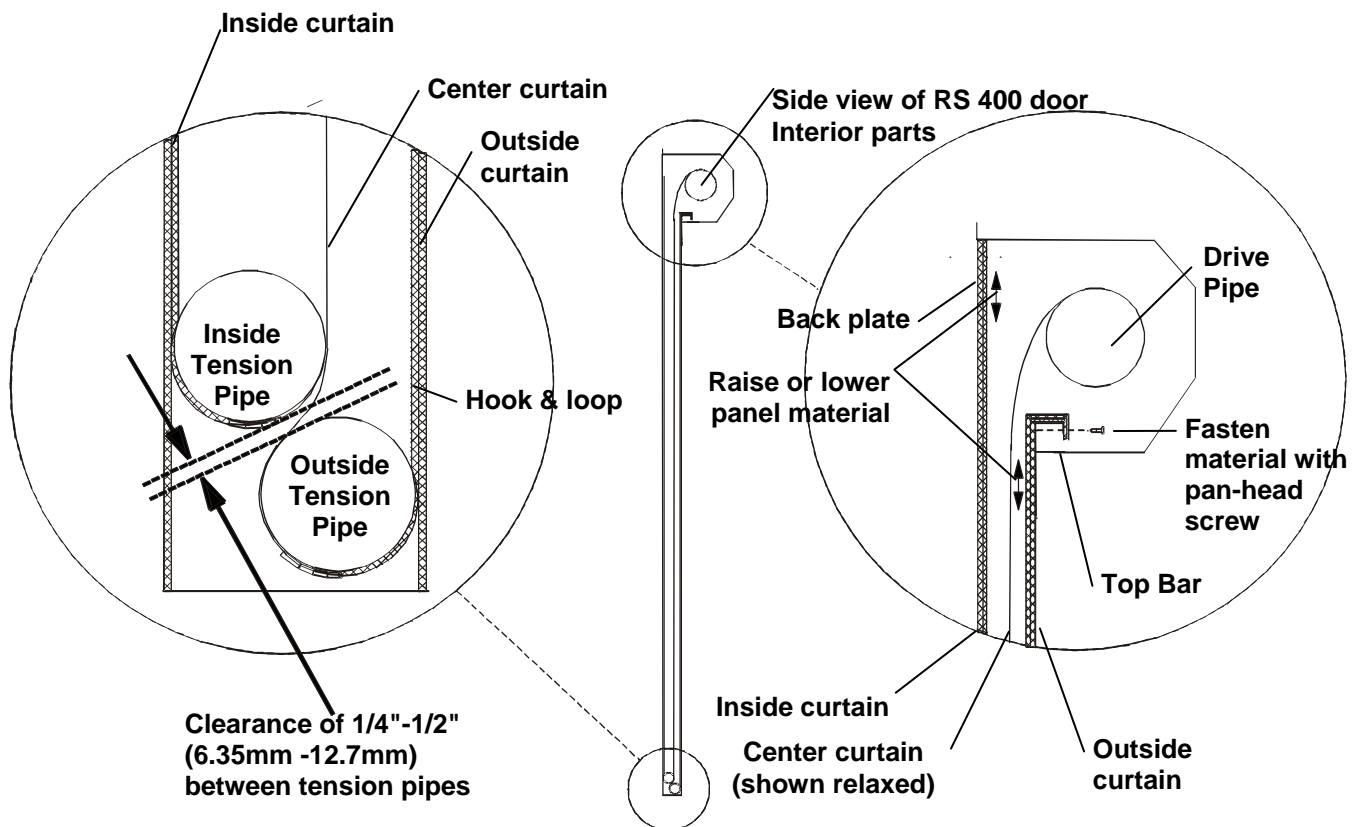

8. Manaras Optional Parts

Mounting Plate, Galvanized	Optional - (Manaras Operators ONLY)
Mounting Plate, Aluminum	Optional - (Manaras Operators ONLY)
Safety Cover, NEMA 1	Optional - (Manaras Operators ONLY)
Radio Remote Receiver	Optional - (Manaras Operators ONLY)
Radio Remote Transmitter	Optional - (Manaras Operators ONLY)
Motion Detector, All Motion	Optional - (Manaras Operators ONLY)
Motion Detector, Programmable	Optional - (Manaras Operators ONLY)
Loop Detector, Single Loop	Optional - (Manaras Operators ONLY)
Loop Detector, Dual Loop	Optional - (Manaras Operators ONLY)
Switches	
Push-Button Switch (Additional)	One included with Door; Extra switches Optional
3 Position Switch, encl button (Open / Close / Stop)	Optional -
3 Position Switch, <u>with Lockout</u>	Optional -
Ceiling Pull Switch, SPST	Optional -
Open / Close Indicator Switch Assembly	Optional -
Photo Eyes	Optional - (Safety Beams)

